



SWING FRAME GRINDERS



One Vulcan Drive, Helena, AL 35080 | (205) 663-0732
sales@vulcangroup.com | www.vulcangroup.com

CG Series Swing Frame Grinders

The Live Shaft high-speed CG-Series of swing frame grinders are rugged, heavy-duty machines with full lateral movement for use in foundries and steel mills. The exclusive **Fox®** Lead Head is an additional option that enables the operator to place a 150-200 lbs of weight over the wheel to dramatically increase productivity.



Cup Wheel Swing Frame Grinders

Cup Wheel Swing Frame Grinders are used for grinding gate stubs, riser pads, parting lines and core fins. These units provide a smoother finish comparable to swing frame grinders with type 1, straight wheels and generally outperform portable grinders 3 to 1.



Fox® 4-CG

Fox® 8-CG

Fox® 10-CG

Wheel Size	24 in x 2 in to 3 in x 12 in (610mm x 50mm to 76mm x 305mm)	16in x 2in to 2½in x 6in (406mm x 60mm to 64mm x 152mm)	12in x 1in to 2in x 1¼in (305mm x 25mm to 50mm x 32mm)
Wheel Speed	12,500 SFPM	12,500 SFPM	9,500 SFPM
Motor	25HP (19kW)	20HP (15kW)	15HP (11kW)
Weight	1,200 lbs (544 kg)	725 lbs (329 kg)	370 lbs (168 kg)
Length	68 in (1727 mm)	61 in (1549 mm)	42 in (1067 mm)

Fox® 18-95

Wheel Size	8 in x 3 in x 7/8-9TPI Type 6 straight cup with threaded insert. Does not require a wheel nut. <i>(Type 6 straight cup plain hole version optional)</i>
Wheel Speed	9,500 SFPM
Motor	10HP (7.5kW)
Drive	Single Speed Pulley Drive

Live Shaft Spindle

The live shaft spindle design has the pulley and wheel flanges mounted to the shaft, and all rotate together, hence the term "live shaft". To change the wheel on this design the door on the wheel guard is opened, the loose flange removed, the wheel stub removed and replaced with a new wheel and blotters, the loose flange replaced and secured and the door closed and secured. Typically about a 5 minute change time.



Dead Shaft Swing Frame Grinders

The Dead Shaft High Speed Swing Frame Grinder is a rugged, heavy-duty, high speed grinder with full lateral movement for use in foundries and steel mills. The Fox® #4 is a high speed, dead shaft grinder that is ideal for grinding castings, billets, ingots and forgings.

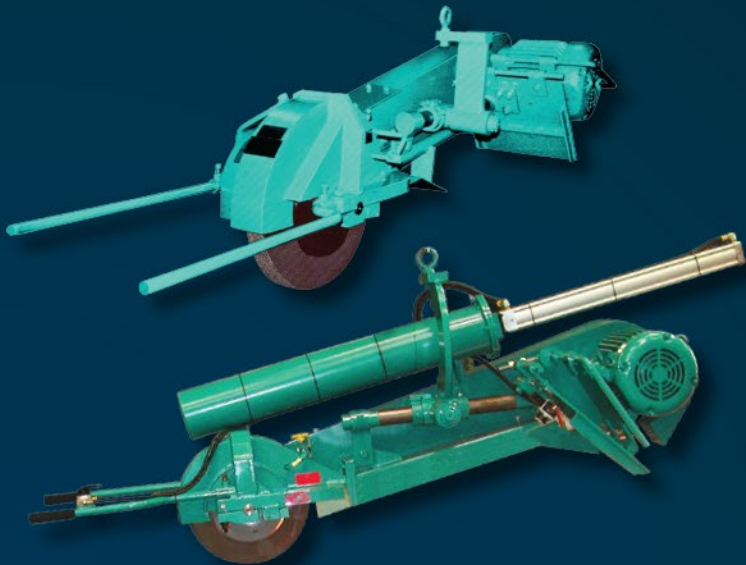

Fox® 4 Dead Shaft

Wheel Size	24 in x 2 in to 3 in x 12 in (610mm x 50mm to 76mm x 305mm)
Wheel Speed	12,500 SFPM (63 m/s) Standard 9,500 SFPM (50 m/s) On Request
Motor	25 HP (19 kW) totally enclosed fan-cooled motor
Drive	Two-Step pulley drive
Weight	Approximately 1,200 lbs (544 kg)
Length	68 in (1727 mm) from center of motor to center of spindle

Dead Shaft Spindle

With the "dead shaft" design, the shaft is clamped in a yoke and does not rotate, hence the term "dead shaft". The pulley and wheel flanges are mounted to the housing and rotate together. To change the wheel the spindle must be dropped out into a wheel change fixture and typically replaced with a second spindle on which a new wheel has already been mounted. Typically about a 15 to 20 minute change time.



Standard Features

- Designed for severe-duty environments
- Dead-man switch and electrical controls mounted on machines for operator safety
- Fixed Spindle Speed
- Spindle and bearings are sealed
- High strength alloy steel shaft
- Acme threaded wheel nut and housing to resist sticking caused by dirt on Dead Shaft models
- The motor is mounted on a pivot mechanism for ease of belt tension
- Electrical package included

Options

Lead Head System

The Lead Head is a pneumatically controlled system that enables the operator to place 150-200 lbs of weight over the grinding wheel.

This system includes the lead head air cylinder, weight and weight tube complete as an assembly. (See back for further explanation)

- 4CG model uses 200 lb (91 kg) weight
- 8CG model uses 150 lb (68 kg) weight
- 10CG model, Lead Head System is not available

Two-Step Pulley Drive

Two-Step Pulley Drive uses a belt interlock mechanism for ease of adjustment of wheel speed change. (See back for further explanation)

**Not all options are available for all models of grinders.*



LEAD HEAD SYSTEM

Weight In Balance Position

Machine is balanced with the lead weight retracted, enabling the operator to easily move the machine into grinding position.

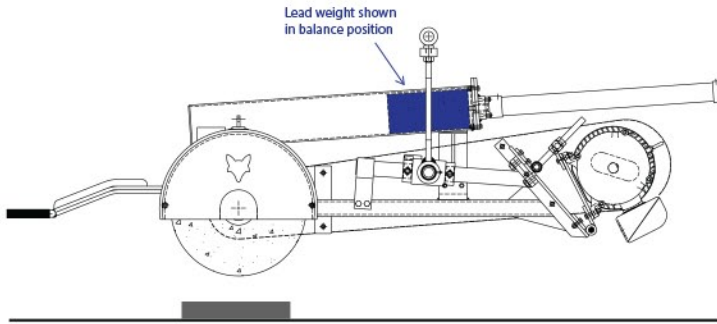

Weight In Grinding Position

The operator activates the block valve, causing the weight to be positioned over the grinding wheel. This applies 150-200 lbs of down force which increases metal removal.

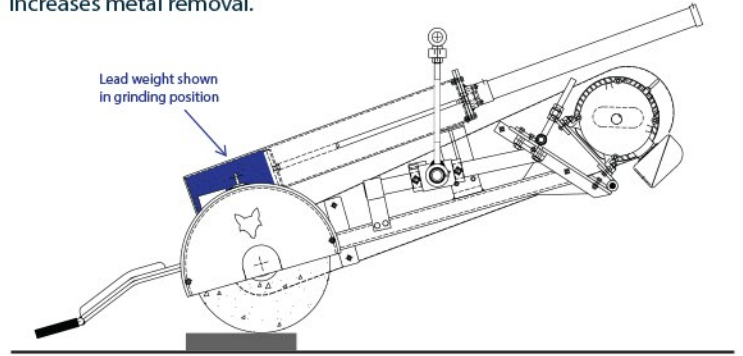

TWO SPEED PULLEY DRIVE

New Wheel Position

The machine is set up for the starting SFPM rate with a new wheel. The belts are on the first (outside) step and are contained by the end of the safety interlock. They cannot be moved to the second step because the interlock will hit the wheel if an attempt is made to move it.

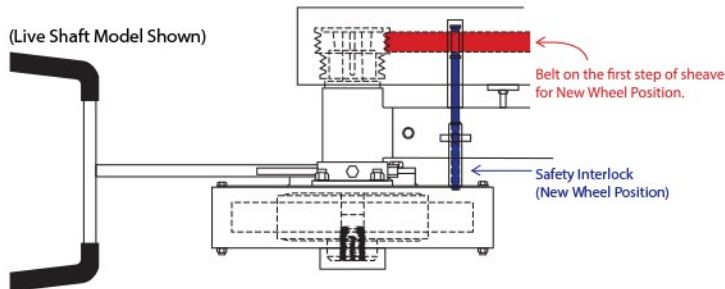

Worn Wheel/Speed Change Position

Once the wheel has worn to the "Speed Change Size," the interlock can be moved and the belts can be transfer to the second (inside) step, increasing the RPM and recovering the starting SFPM for improved efficiency. When the wheel is completely worn out, the sequence is reversed. A new wheel cannot be mounted until the interlock is moved back to the new wheel position.

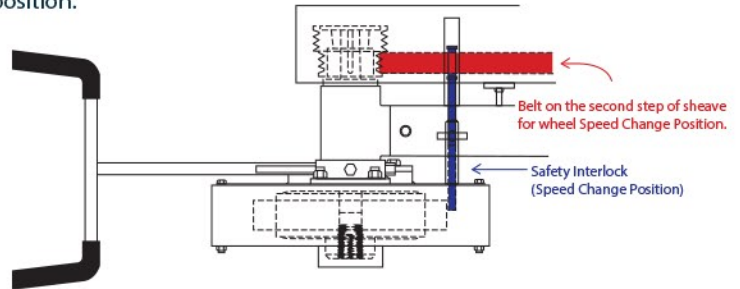

Scan the Code 

Use your smart phone and scan this QR code to get more info and video of the 8-CG Swing Frame

Basic machines include Live Shaft & Dead Shaft swing frame grinders. Ancillary equipment can be added. Options include Casting Positioners and Material Handling Equipment



For more information, images and videos on Fox® Swing Frame Grinders visit our website and enter the address below:

<http://www.vulcangroup.com>